

EUR1 Extra Heavy Duty

[EUR1 XHDv1] 1.200 x 800 x 150 mm



Sanitized & Clean	ISPM-15 Compliant	Environmentally Friendly	100% Recyclable	One way, Single Use	Safe to Handle	80% Vibration Absorption

Dimensions		Forklift Handling		Packaging	
Length	1.200 mm	Forklift Truck	Yes	Stack	15 / 17 / 19 pallets
Width	800 mm	Stacker	Yes	Options	
Height	150 mm	Side Loader	Yes	Moisture Resistant	Yes
Weight	4,6 kg	Low Lift Walkie/Rider	Yes	Paraffined Wax	Option
		Order Picker - Dual Forks	Yes	Anti-Slip Coating	Option
		Pallet Jack	Yes	Custom Print	Option

Performance and Load Capacity			Max. Load [kg]
Application	Load Distribution		
Static	Even ¹		4.500
	Non-even ²		3.000
	Concentrated ³		400
Dynamic	Even		1.500
	Non-even		1.000
	Concentrated		300
Open Rack	Even		700
	Non-even		500
	Concentrated		250
When stacking loaded pallets on a solid, even surface, the bottommost pallet must not exceed			4.500

¹ Compact, sturdy, well integrated, wrapped loads (e.g., large boxes, interlocked medium boxes, foil-wrapped small boxes)

² Loose unwrapped loads applying unbalanced force to the pallet (e.g. sacks)

³ Loads not covering the full pallet loading area, positioned (e.g. large cylinders)

EUR1 Extra Heavy Duty

[EUR1 XHDv1] 1.200 x 800 x 150 mm

3D View

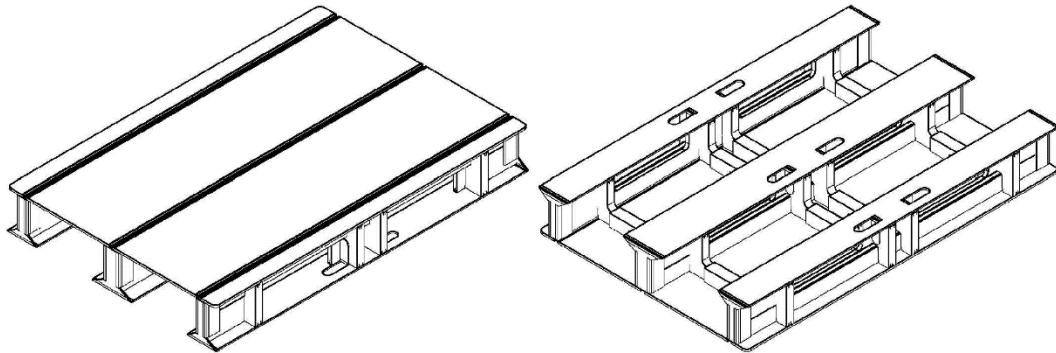

Technical Drawing

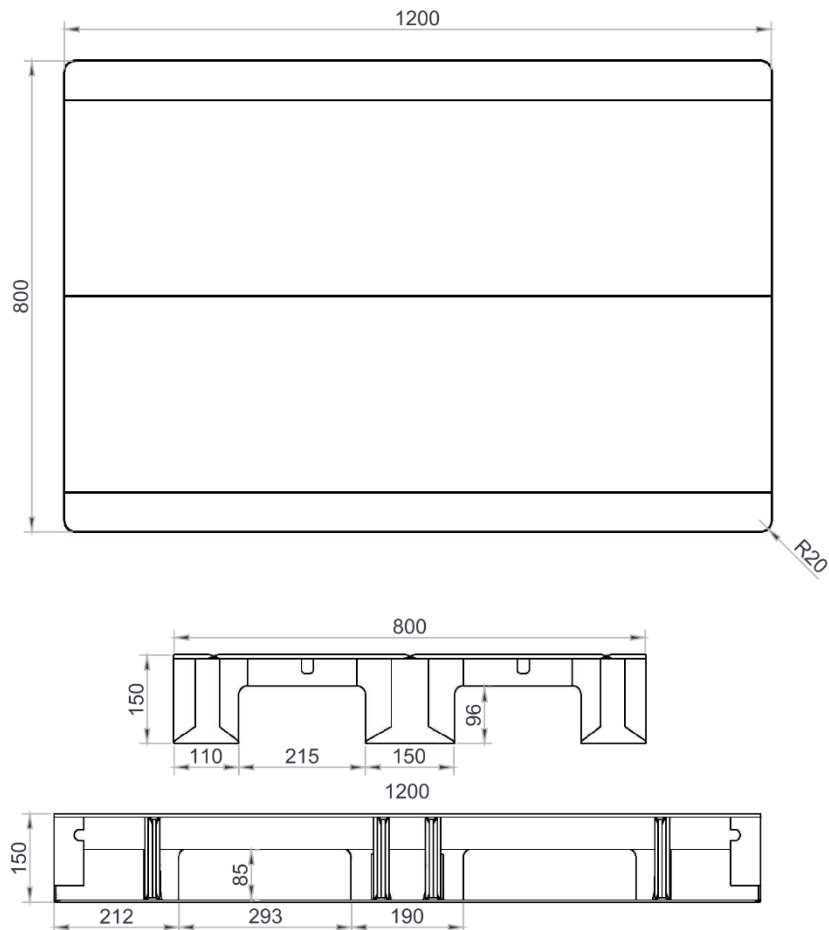

Disclaimer: The figures provided are estimates and are based on results of flatbed compression tests conducted by an independent certification body in collaboration with KraftPal experts and in accordance with the Safe Working Load (SWL) guidelines for standard pallet application. However, it is important to note that these figures may not be applicable for all uses and it is strongly advised that before using the pallets, you consult with KraftPal's expert sales team and perform internal tests to validate the pallet's suitability and safety for the intended use. Please also kindly note that while we believe that the figures expressed herein present fair general estimates as calculated by independent certification body, we, as Kraftpal, are not responsible for these estimates and are not taking any liability whatsoever in relation to estimates.